

SKRL Remote Shotgun Swivel (SKRL-P4, SKRL-MP9)

Description:

The SKRL Remote Shotgun Swivel is a self-rotating tool designed to be used as part of the Lightweight Striker automated shotgun system and is intended to limit the maximum reaction force to within the allowable range of the system. Two standard models are available. The SKRL-P4 model is rated for 10K psi and is supplied with a 1/4 npt female inlet. The head has (2) M16x1.5 nozzle ports. Maximum orifice size for the 10K swivel is .042" which provides a maximum flow rate of 9 gallons per minute and a reaction force of approximately 45 lbs. The SKRL-MP9 model is rated for 20K psi and has a 9/16 inch medium pressure female inlet. The head has (2) M12x1.25 nozzle ports. The maximum orifice size for the 20K swivel is .028" which provides a maximum flow rate of 6 gallons per minute and a reaction force of approximately 42 lbs. The SKRL uses automatic transmission fluid (ATF) as a lubricant for the bearings and speed control components. It can be flushed/refilled with ATF through the fill port using a syringe. This is recommended after every 20 to 40 hours of operation.

Operation:

The SKRL should always be used with a dump or pressure shut-off mechanism, so that pressure can be rapidly released. Install the desired nozzle size into the head; we recommend using Swagelok® Blue Goop anti-seize on the nozzle threads to avoid galling. Attach the SKRL into the clamp on the automated shotgun wrist. Flush the high pressure hose before connecting to the SKRL inlet. Check that the dump mechanism functions correctly before going to operating pressure. The SKRL high pressure seal may initially leak at lower pressure, but the seal should pop shut as pressure is increased. To set the operating pressure, the SKRL operator should close the dump and slowly increase the pressure, insuring that the unit is correctly set up and stable while under jet thrust loading. The unit should not slide around as the tool is articulated through the entire range of motion. The SKRL head should be within 2 to 8 inches of the surface, depending on how difficult it is to remove the material.

Troubleshooting:

High Pressure Seal Leak: If water is coming out of the slots in the body, see if it is coming out the bottom of the slot (near the head) or the top of the slot (near the inlet end). If it is coming out near the inlet end, it is the inlet connection that is leaking. If it is coming out the bottom of the slot, it is the high pressure seal that is leaking.

Follow the directions below to replace the carbide seat and high pressure seal; if it still leaks then the shaft end may be damaged and needs to be repaired or replaced. **Seals wear out quickly:** When the life of the high pressure seal becomes noticeably less, the seal holder needs to be replaced. Also replace the carbide seat if it has not been replaced with each seal change. Very rarely, the spring that controls the speed of the tool will break, allowing the tool to spin too fast and quickly wear out the seal.

Will not rotate: Check the nozzles to see if they are plugged or partially plugged. To clean them, they must be removed from the head; it does not do any good to poke the material plugging the nozzle back into the head. Check that the nozzles are the correct size based on the desired operating pressure and flow rate. If all of these things appear to be correct, the tool may need to be disassembled and repaired. If the tool has just been rebuilt, and the tool starts to spin but stops as pressure is increased, the bearing RJ 007 is installed backwards and the tool must be disassembled and fixed.

Maintenance: *Blow out all water with compressed air before storing tool!

To replace the high pressure seal:

- (10K only) Remove the Adapter (SKRL 205) from the inlet port of the Body using a 1/4" Allen wrench.
- Remove the O-Ring (BJ 072) from groove in Body. It is easiest to push it inward from the top of the slot.
- Use two picks inserted thru the slots to pry the Seal Holder (BC 120-C) and Inlet Seat (BC 122) up and out of the Body.
- Remove the H.P. Seal (FT 012) and Carbide Seat (FT 011). Inspect the Seal Holder for grooves or cracks. If it is badly grooved on one end, it can be flipped over or replaced.
- Inspect Carbide Seat (FT 011) for chips or erosion. Replace if damaged. Inspect end of shaft for dings.
- Check that O-Ring (BC 123) is in groove of Inlet Seat (BC 122). Place Seal Holder (BC 120-C) on top of Inlet Seat (against the side with the O-Ring).
- Apply grease to a new H.P. Seal and install in Seal Holder. The end with the O-Ring and metal cone faces away from the Carbide Seat. Apply grease to the face of the Carbide Seat and install against H.P. Seal.
- Balance the Inlet Seat and Seal Holder on fingertip; turn swivel upside down (nozzles up) and slide the Inlet Seat and Seal Holder into the Body. Make certain that the Carbide Seat stays in Seal Holder.
- Turn the swivel inlet end up; the Inlet Seat and Seal Holder should be far enough into Body to install the O-Ring into the groove in Body.
- (10K only) Install the Adapter (SKRL 205) into the inlet port of the Body using Loctite 242 Blue.

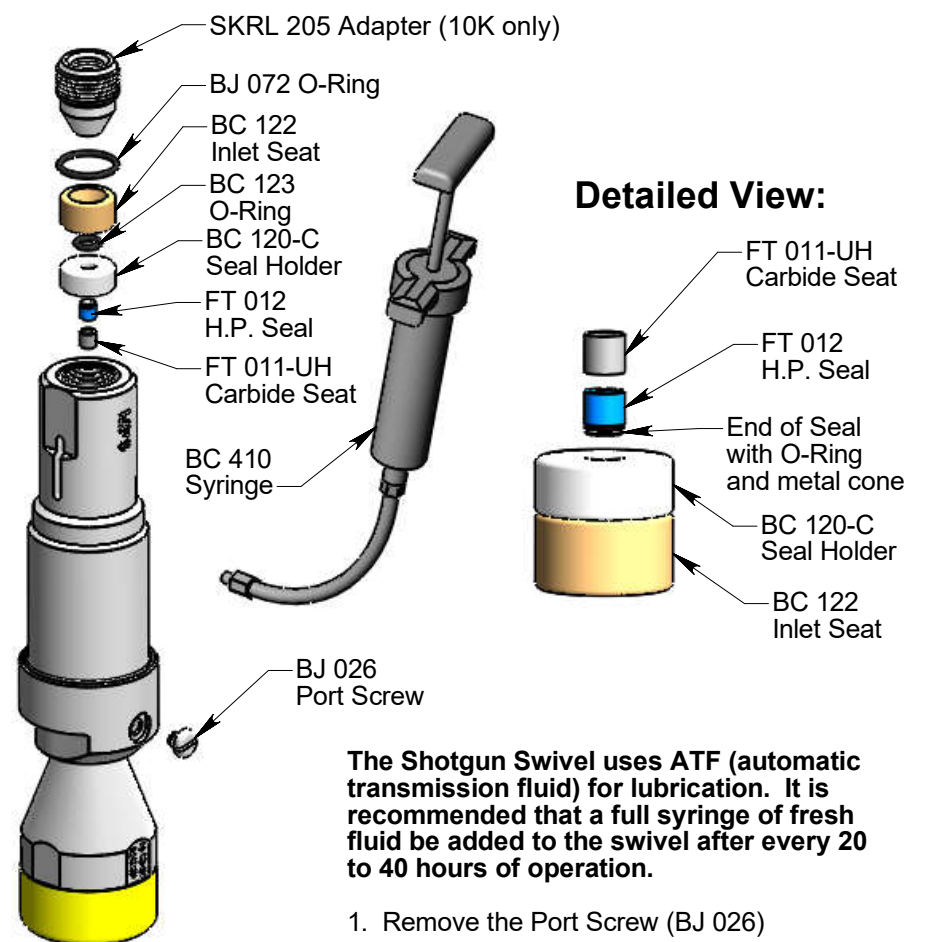

The Shotgun Swivel uses ATF (automatic transmission fluid) for lubrication. It is recommended that a full syringe of fresh fluid be added to the swivel after every 20 to 40 hours of operation.

- Remove the Port Screw (BJ 026)
- Thread the Syringe (BC 410) into the port.
- Squeeze fresh ATF into the swivel; excess will come out the slots.
- Remove Syringe and install Port Screw.

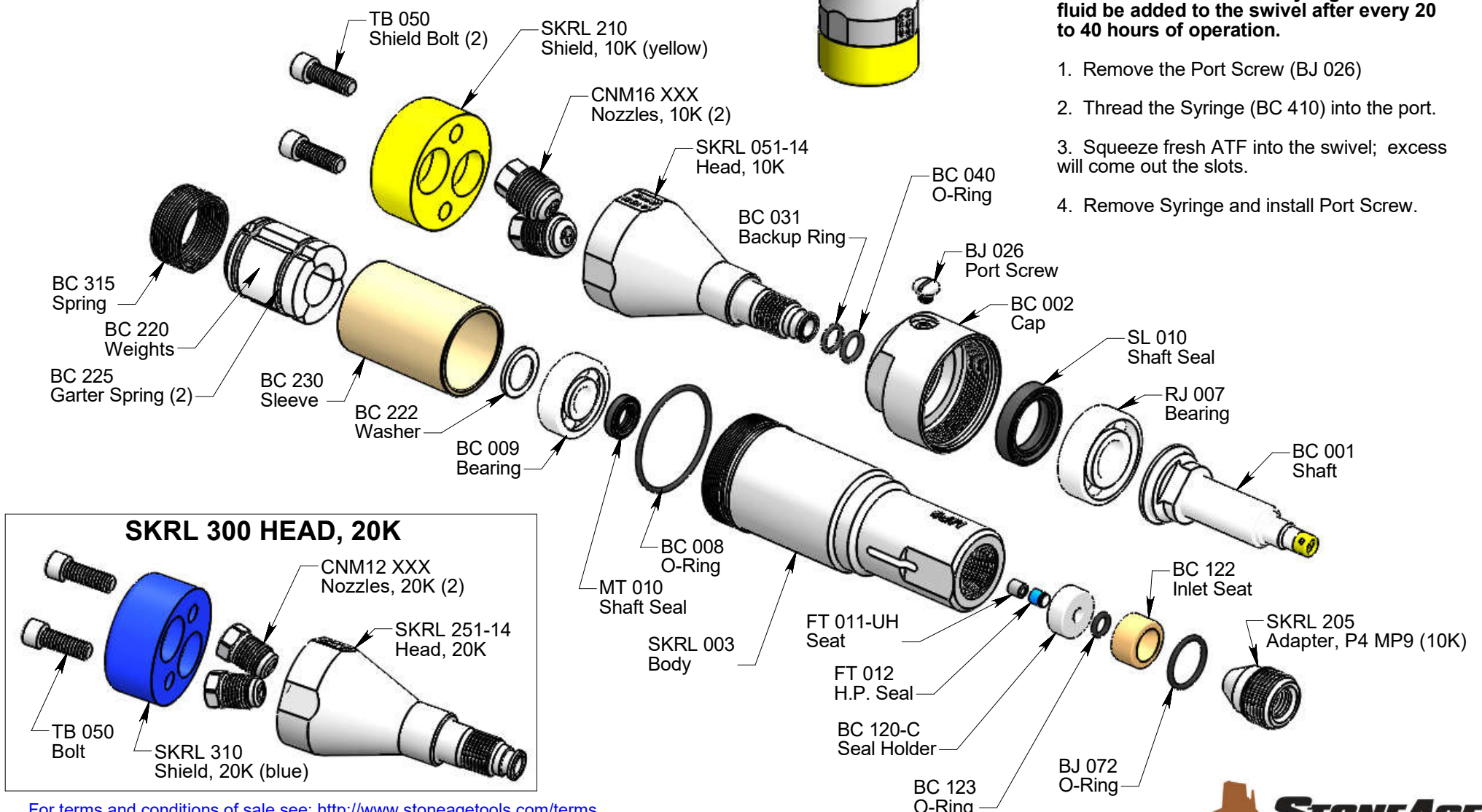

For terms and conditions of sale see: <http://www.stoneagetools.com/terms>

For limited warranty see: <http://www.stoneagetools.com/warranty>

For applicable patents see: <http://www.sapatents.com>

SKRL Remote Shotgun Swivel (SKRL-P4, SKRL-MP9)

Description:

The SKRL Remote Shotgun Swivel is a self-rotating tool designed to be used as part of the Lightweight Striker automated shotgun system and is intended to limit the maximum reaction force to within the allowable range of the system. Two standard models are available. The SKRL-P4 model is rated for 10K psi and is supplied with a 1/4 npt female inlet. The head has (2) M16x1.5 nozzle ports. Maximum orifice size for the 10K swivel is .042" which provides a maximum flow rate of 9 gallons per minute and a reaction force of approximately 45 lbs. The SKRL-MP9 model is rated for 20K psi and has a 9/16 inch medium pressure female inlet. The head has (2) M12x1.25 nozzle ports. The maximum orifice size for the 20K swivel is .028" which provides a maximum flow rate of 6 gallons per minute and a reaction force of approximately 42 lbs. The SKRL uses automatic transmission fluid (ATF) as a lubricant for the bearings and speed control components. It can be flushed/refilled with ATF through the fill port using a syringe. This is recommended after every 20 to 40 hours of operation.

Operation:

The SKRL should always be used with a dump or pressure shut-off mechanism, so that pressure can be rapidly released. Install the desired nozzle size into the head; we recommend using Swagelok® Blue Goop anti-seize on the nozzle threads to avoid galling. Attach the SKRL into the clamp on the automated shotgun wrist. Flush the high pressure hose before connecting to the SKRL inlet. Check that the dump mechanism functions correctly before going to operating pressure. The SKRL high pressure seal may initially leak at lower pressure, but the seal should pop shut as pressure is increased. To set the operating pressure, the SKRL operator should close the dump and slowly increase the pressure, insuring that the unit is correctly set up and stable while under jet thrust loading. The unit should not slide around as the tool is articulated through the entire range of motion. The SKRL head should be within 2 to 8 inches of the surface, depending on how difficult it is to remove the material.

Troubleshooting:

High Pressure Seal Leak: If water is coming out of the slots in the body, see if it is coming out the bottom of the slot (near the head) or the top of the slot (near the inlet end). If it is coming out near the inlet end, it is the inlet connection that is leaking. If it is coming out the bottom of the slot, it is the high pressure seal that is leaking.

Follow the directions below to replace the carbide seat and high pressure seal; if it still leaks then the shaft end may be damaged and needs to be repaired or replaced.

Seals wear out quickly: When the life of the high pressure seal becomes noticeably less, the seal holder needs to be replaced. Also replace the carbide seat if it has not been replaced with each seal change. Very rarely, the spring that controls the speed of the tool will break, allowing the tool to spin too fast and quickly wear out the seal.

Will not rotate: Check the nozzles to see if they are plugged or partially plugged. To clean them, they must be removed from the head; it does not do any good to poke the material plugging the nozzle back into the head. Check that the nozzles are the correct size based on the desired operating pressure and flow rate. If all of these things appear to be correct, the tool may need to be disassembled and repaired. If the tool has just been rebuilt, and the tool starts to spin but stops as pressure is increased, the bearing RJ 007 is installed backwards and the tool must be disassembled and fixed.

Maintenance: *Blow out all water with compressed air before storing tool!

To replace the high pressure seal:

- (10K only) Remove the Adapter (SKRL 205) from the inlet port of the Body using a 1/4" Allen wrench.
- Remove the O-Ring (BJ 072) from groove in Body. It is easiest to push it inward from the top of the slot.
- Use two picks inserted thru the slots to pry the Seal Holder (BC 120-C) and Inlet Seat (BC 122) up and out of the Body.
- Remove the H.P. Seal (FT 012) and Carbide Seat (FT 011). Inspect the Seal Holder for grooves or cracks. If it is badly grooved on one end, it can be flipped over or replaced.
- Inspect Carbide Seat (FT 011) for chips or erosion. Replace if damaged. Inspect end of shaft for dings.
- Check that O-Ring (BC 123) is in groove of Inlet Seat (BC 122). Place Seal Holder (BC 120-C) on top of Inlet Seat (against the side with the O-Ring).
- Apply grease to a new H.P. Seal and install in Seal Holder. The end with the O-Ring and metal cone faces away from the Carbide Seat. Apply grease to the face of the Carbide Seat and install against H.P. Seal.
- Balance the Inlet Seat and Seal Holder on fingertip; turn swivel upside down (nozzles up) and slide the Inlet Seat and Seal Holder into the Body. Make certain that the Carbide Seat stays in Seal Holder.
- Turn the swivel inlet end up; the Inlet Seat and Seal Holder should be far enough into Body to install the O-Ring into the groove in Body.
- (10K only) Install the Adapter (SKRL 205) into the inlet port of the Body using Loctite 242 Blue.

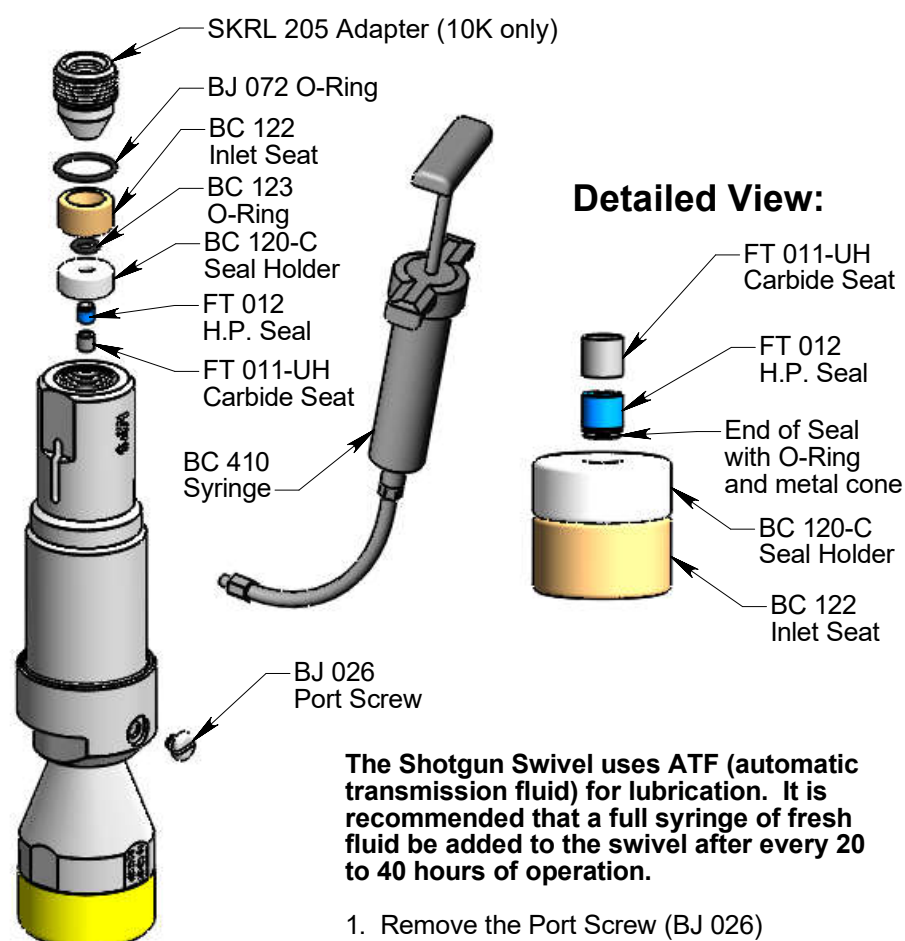

The Shotgun Swivel uses ATF (automatic transmission fluid) for lubrication. It is recommended that a full syringe of fresh fluid be added to the swivel after every 20 to 40 hours of operation.

- Remove the Port Screw (BJ 026)
- Thread the Syringe (BC 410) into the port.
- Squeeze fresh ATF into the swivel; excess will come out the slots.
- Remove Syringe and install Port Screw.

